

ExaVir™ Load

Version 3

**Quantitative Determination
of Reverse Transcriptase Activity**

INSTRUCTIONS FOR USE

For Colorimetric Detection

Cat # 55011

CE

CAVIDI

Table of Contents

Intended use.....	2
Principles of the ExaVir™ Load kit.....	2
Components.....	2
Assembling and disinfecting the separation equipment and sample box.....	3
Kit storage and shelf life.....	3
Plasma sample collection, preparation and storage.....	4
Preparation and storage of controls.....	4
Precautions.....	4
Performance.....	4
Calculation of results.....	5
Traceability of standard.....	5
Reference values.....	5
Symbols.....	5
Standard set-up of the 96-well RT Reaction Plate.....	5
Quick guide to the ExaVir Load procedure.....	6
Step-by-step instructions.....	7
Day one.....	7
Day two.....	11
References.....	13



Intended Use

The ExaVir™ Load kit is intended for determination of the activity of the enzyme Reverse Transcriptase (RT) as a marker of retroviral replication. The ExaVir Load kit is not intended to be used as a screening test for HIV-1 nor is it to be used as a diagnostic test to confirm the presence of HIV-1 infection.

Principles of the ExaVir™ Load Kit

The ExaVir Load kit procedure is divided into two main parts: the Separation and the RT-assay. In the Separation part the plasma is first treated to inactivate cellular enzymes. The virus particles are then separated from the plasma by the use of a gel that binds the virion. At this stage disturbing factors present in the plasma, such as antibodies or antiretroviral drugs, are washed away^{1,2}. To obtain the RT, the virion is then lysed and the lysate collected for further analysis in the RT-assay part.

During the RT-assay the lysates are analysed in an ELISA set-up. The principle of this assay is illustrated in figure 1. The figure shows a well in the 96-well RT Reaction Plate, used for the RT-assay, with the RNA template bound to the bottom. A reaction mixture, containing primer and an RT substrate, is added to the plate together with the lysates. If the lysates contain any RT, the enzyme will synthesise a DNA-strand. This product is detected with an alkaline phosphatase (AP) conjugated α -BrdU antibody. The product can then be quantified by addition of a colorimetric AP substrate.

To increase the range of the assay, the lysates are added to the RT Reaction Plate in two different amounts, 150 and 30 μ l. Furthermore, the RT Reaction Plate is read at two different occasions, after 2 to 3 hours and the following day, e.g. small amounts of RT can be detected in the largest volume after the longest developing time.

A serially diluted standard, with a known concentration of recombinant HIV-1 RT, is also added to the plate. The serial dilution is used by the ExaVir Load Analyzer to quantify the RT in the samples.

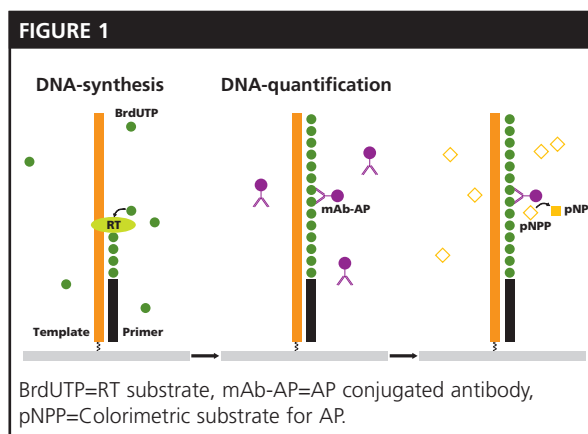

Components

One ExaVir Load kit contains reagents and consumables for analysis of 32 plasma samples, including one positive and one negative plasma control. The reagents and consumables are delivered in two separate boxes.

REAGENTS:

- 1 *Sample Additive* (Reconst. to 4 ml)
- 1 *Separation Gel* (36 ml)
- 1 *Gel Buffer 1 conc.* (120 ml)
- 1 *Gel Buffer 2 conc.* (21 ml)
- 1 *Lysis Buffer* (24 ml)
- 1 *Lysis Buffer Additive* (Reconst. to 24 ml)
- 1 *RT Reaction Plate* (96 wells)
- 1 *RT Reaction Buffer* (12.5 ml)
- 1 *RT Reaction Components* (Reconst. to 4 ml)
- 1 *Dilution Buffer* (24 ml)
- 1 *Dilution Buffer Additive* (Reconst. to 24 ml)
- 1 *HIV-1 rRT Standard* (Reconst. to 6 ml)
- 1 *Plate Wash Buffer conc.* (80 ml)
- 1 *RT Product Tracer* (Reconst. to 12 ml)
- 1 *Product Tracer Dissolvent* (12.5 ml)
- 1 *Substrate Tablet* (15 mg)
- 1 *Substrate Buffer* (30 ml)
- 1 *HIV-1 rRT Standard Sheet*

CONSUMABLES:

- 32 *Plasma Processing Tubes* with separate caps
- 32 *Columns*
- 48 *Storage Tubes*
- 2 *Pieces of Adhesive Tape*
- 1 *Plastic lid for 96-well plate*
- Rubber bands*

EXAVIR LOAD START-UP EQUIPMENT

- NOT SUPPLIED WITH KIT
- Sample Box & Lid*
- Column Holder*
- Waste Collector*
- Lysate Collector*

Collector Tube Rack
 Vacuum Pump
 Waste Container & Lid
 Buffer Dispenser
 Collector Tube Connection
 4x3-litre Wash Buckets
 5-litre Container
 250-ml Bottle
 2-litre Bottle
 Rack containing 96 Storage Tubes
 CD containing ExaVir Load Analyzer

EQUIPMENT REQUIRED BUT NOT PROVIDED

1 In-house positive control (see page 4)
 1 In-house negative control (see page 4)
 Purified water
 Vircon or other relevant disinfectant
 ELISA-plate reader with A₄₀₅ filter
 Incubator set at 33°C
 Freezer set at -14 to -25°C
 End-over-end mixing table
 Vortex
 Single-channel pipettes 100-1000 µl
 Multi-channel pipettes 30-200 µl
 Reservoirs for multi-channel pipettes
 Pipette filter tips (1000 µl)
 Pipette tips (200 µl)
 25 ml Bottle/Tube
 Absorbing paper
 Computer with Microsoft Excel, version 97 or later, and Adobe Reader
 (Plastic Pasteur pipettes)

DESCRIPTION OF COMPONENTS

- The *RT Reaction Plate* has pr(A) (polyriboadenosine) strands covalently bound to the wells.
- The *RT Reaction Components* contains lyophilised odT (oligodeoxythymidine) primer

and BrdUTP (5-bromo-3-deoxyribouridine 5'-triphosphate).

- The *RT Product Tracer* contains lyophilised monoclonal α-BrdUMP (anti bromo-deoxyribouridine monophosphate) antibodies conjugated to alkaline phosphatase.
- The *Substrate Tablet* contains pNPP (paranitrophenylphosphate disodium)

Assembling and Disinfecting the Separation Equipment and Sample Box

Figure 2 illustrates how to assemble the Separation equipment. The columns and tubes are for one-time-use only and must be discarded after use.

Disinfect the Vacuum Pump by wiping it down with 70% ethanol. The Buffer Dispenser must be rinsed first with tap water and then with purified water. Disinfect the Sample Box and all parts of the Separation equipment, except for the Vacuum Pump, by rinsing it with 70% ethanol or other relevant disinfectant.

Rinse the disinfected equipment, except for the Vacuum Pump, with water and let it dry before the next use. Empty the Waste Container after disinfection and add a suitable amount of relevant disinfectant before the next use.

Kit Storage and Shelf Life

- Store the kit reagents at between -14 and -25°C until use. If stored at those conditions the ExaVir Load kit reagents can be used until the expiry date found on the kit label.

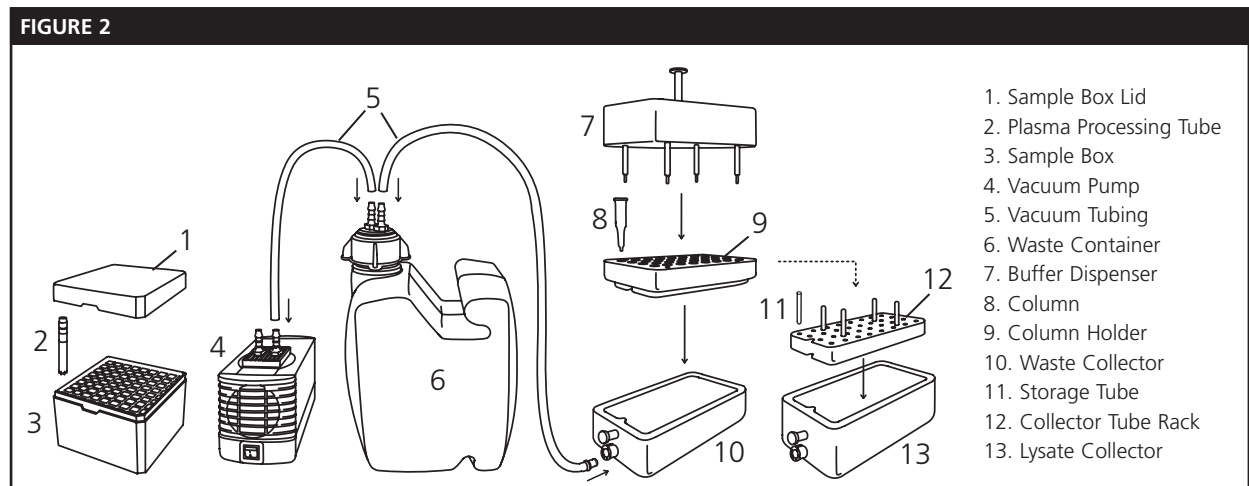

- If delivered unfrozen, the kit should be refrozen and stored between -14 and -25°C or stored at 4 to 8°C for usage within a week.
- Store the kit consumables at between 18 and 33°C until use.
- All kit components are for one-time-use only. Discard any remaining reagents after the ExaVir Load kit procedure has been performed.

Plasma Sample Collection, Preparation and Storage

- 1 ml plasma is needed for analysis in the ExaVir Load kit.
- Plasma should be prepared from EDTA anticoagulated whole blood.
- For optimal results, plasma should be separated from cells within four hours of the collection of the blood. Significant delays (more than six hours) can lead to inaccurate results.
- It is important to avoid white blood cell contamination.
- The plasma samples must be frozen once before analysed in the ExaVir Load kit.
- Storage of plasma samples should be at or below -20°C.
- Long-term storage (more than six months) of plasma samples should be at or below -60°C.
- Avoid repeated freezing and thawing cycles.
- Samples should be vortexed for five seconds prior to use.
- Do not use samples that are grossly lipaemic.

Preparation and Storage of Controls

PREPARATION OF IN-HOUSE HIV POSITIVE CONTROL

As human material cannot be included in the kit, prepare about 100 ml of a pool of EDTA plasma by mixing samples with high and low HIV RT activity levels. The pool should correspond to approximately 115 fg/ml of RT. If no plasma with determined RT amount is available we recommend preparing a pool that corresponds to approximately 25000 copies/ml. Aliquot the material into 1.2 ml portions and use 1 ml of one portion as positive control with every ExaVir Load kit.

PREPARATION OF IN-HOUSE NEGATIVE CONTROL

Prepare about 100 ml of a pool of EDTA plasma from healthy blood donors. Aliquot the material into 1.2 ml portions and use 1 ml of one portion as negative control with every ExaVir Load kit.

STORAGE OF CONTROLS

Long-term storage of the controls is recommended at or below -60°C. Do not store controls at -20°C during more than six months.

Precautions

- For *in vitro* diagnostic use.
- Observe normal precautions required for handling infectious material and laboratory reagents.
- Do not combine components from kits with different LOT numbers.
- Do not expose the kit components to direct sunlight or a temperature above 37°C during laboratory work.
- The Separation equipment should be used with the supplied Vacuum Pump to standardise the system.

Performance

ANALYTICAL SENSITIVITY

The analytical sensitivity is 1 fg/ml, based on the average OD value of the RT-assay buffer blank wells plus two standard deviations.

MEASURING RANGE

The measuring range is 1 to 3000 fg/ml. The upper detection limit is dependent on the plate reader used, since it is defined as the fg value corresponding to the highest OD value still within the plate reader's linear measuring range. A plate reader with a larger linear measuring range will give a higher upper detection limit. 3000 fg/ml is based on a plate reader with an upper limit of 2.5 OD.

ANALYTICAL SPECIFICITY

There is no lentivirus-like RT present in plasma from healthy humans. Our studies show that the sample treatment step eliminates any non-HIV associated RT activity present in the plasma that might give false positive signals¹.

PRECISION

HIV positive samples with different fg/ml values were analysed at five independent occasions. Each sample was analysed in four replicates in each run. A summary of the results for four of the samples is presented in the table.

Concentration (fg/ml)	Within-assay CV* (%)	Between-assay CV* (%)
177	4	2
67	6	2
28	6	3
10	8	3

INTERFERENCES

Antiretroviral drugs could be considered as potential inhibitors. However, studies do not show that they act as inhibiting factors in the ExaVir Load kit^{2,3}.

Calculation of Results

Calculation of results from the ExaVir Load kit shall be performed using the ExaVir Load Analyzer. This software automatically calculates the amount of RT in the samples. The amount is calculated through a standard curve generated by an eleven point serial dilution of a known amount of recombinant HIV-1 RT. The results are expressed in fg RT/ml plasma and in RNA copies/ml equivalents. For further information please refer to the ExaVir Load Analyzer Instructions for Use.

Traceability of Standard

The purified wild type BH10 HIVrRT used to prepare the HIV-1 rRT Standard included in the ExaVir Load kit was prepared as described in Weber et al⁴. The stated protein amount, expressed as fg, is based on the assumption of total purity and that the preparation is composed of a 117 kDa heterodimer.

Reference Values







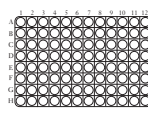

175 plasma samples from healthy Swedish and South African blood donors were analysed in the ExaVir Load kit. 100% of the samples were reported as below the lower detection limit.

Symbols - used in instructions for use and kit labelling

 : Incubation time, in this case 20 minutes.

*CV= coefficient of variation











 : The figure is an illustration of the 96-well RT Reaction Plate or Storage Tube Rack with well/Storage Tube A1 in the upper left corner. Arrows illustrate a transfer from the Storage Tubes to the RT Reaction Plate or from one Storage Tube to another.

-  Manufacturer
-  Expiry date
-  Article number
-  LOT number
-  Keep away from direct light
-  For *in vitro* diagnostic use
-  Number of determinations
-  Temperature limitation

Cat# ExaVir Load kit article number

Standard Set-up of the 96-well RT Reaction Plate

	1	2	3	4	5	6	7	8	9	10	11	12
A	1	1	9	9	17	17	25	25	S9	S9	S1	S1
B	2	2	10	10	18	18	26	26	S10	S10	S2	S2
C	3	3	11	11	19	19	27	27	S11	S11	S3	S3
D	4	4	12	12	20	20	28	28	Bb	Bb	S4	S4
E	5	5	13	13	21	21	29	29	Bb	Bb	S5	S5
F	6	6	14	14	22	22	30	30	Bb	Bb	S6	S6
G	7	7	15	15	23	23	P	P	Bb	Bb	S7	S7
H	8	8	16	16	24	24	N	N	Bb	Bb	S8	S8

-  = 150 µl Lysate
-  = 30 µl Lysate
-  = 150 µl Standard
-  = 30 µl Standard
-  = 150 µl Buffer blank
-  = 30 µl Buffer blank
-  = Sample number
-  = Standard number
-  = Positive control
-  = Negative control
-  = Buffer blank

Quick Guide to the ExaVir Load Procedure

Day one

1. Collect and thaw components, controls and samples.

2. Add 4 ml water to *Sample Additive*. Vortex. Label 32 Plasma Processing Tubes. Add 100 µl *Sample Additive* to each tube. Add 1 ml plasma sample or control to each tube. Add caps, vortex and incubate for 20 min. in the dark at room temperature**.

3. Prepare the Separation equipment. Label 32 Columns and Storage Tubes.

4. After 20-min. incubation - add 1 ml *Separation Gel* to each tube. **Shake *Separation Gel* bottle between each transfer.** Mix for 30 min. at room temperature**.

5. Add *Gel Buffer 1 conc* to 2-litre bottle. Rinse *Gel Buffer 1 conc* bottle with 100 ml water and add to 2-litre bottle. Add 1100 ml water to the 2-litre bottle. Mix. Add *Gel Buffer 2 conc* and 260 ml water to 250-ml bottle. Mix. Dissolve the *Lysis Buffer Additive* in 5 ml *Lysis Buffer*. Vortex and transfer back to *Lysis Buffer* bottle. Vortex.

6. After 30-min. incubation, vortex each tube and pour into corresponding Column. Apply vacuum and suck gels dry. Wash gels 4 times with Gel buffer 1.

7. Wash gels 1 time with all Gel buffer 2. Suck gels completely dry before proceeding.

8. Connect the Lysate Collector to the Waste Container and put the Collector Tube Rack with the Storage Tubes into it. **Make sure that the valve is open and that the Vacuum Pump is turned off.** Move the Column Holder to the Lysate Collector. Vortex *Lysis Buffer*. Add 250 µl *Lysis Buffer* to each Column. Wait 2 minutes. Suck the gels dry by turning on the Vacuum Pump and closing the valve for 7 seconds. Open the valve and close it again for 7 seconds. Move the Storage Tubes to the Storage Tube Rack.

9. Dissolve the *Dilution Buffer Additive* in 5 ml *Dilution Buffer*. Vortex and transfer back to *Dilution Buffer* bottle. Vortex.

10. Add 4 ml *RT Reaction Buffer* to *RT Reaction Components*. Vortex. Mix 1.8 ml dissolved *RT Reaction Components* and 7.2 ml *Dilution Buffer* in an empty tube/bottle (2RM). Transfer 30 µl dissolved RT Reaction Components to rows 1, 3, 5, 7, 9 and 11 of the *RT Reaction Plate*. Transfer 150 µl 2RM to rows 2, 4, 6, 8, 10 and 12 of the *RT Reaction Plate*.

11. Add 6 ml *Dilution Buffer* to *HIV-1 rRT Standard*. Vortex.

Add 300 µl *Dilution Buffer* to 16 empty Storage Tubes, positioned in rows 10 and 12 of the Storage Tube Rack. Make a serial dilution in Storage Tubes A12 to C10 by transferring 200 µl dissolved *HIV-1 rRT Standard* to Storage Tube A12. Change tip and mix 5 times and transfer 200 µl to Storage Tube B12 etc, all the way to H12 and then continuing to A10, B10 and C10.

12. Add lysates, buffer blanks and standard to *RT Reaction Plate* in 150- and 30-µl portions. Seal *RT Reaction Plate* and incubate for 18 to 24 hours at 33°C.

Day two

13. Collect and thaw components.

14. Mix 2 litres of water and *Plate Wash Buffer conc* in the 5-litre container. Adjust to 5 litres with water. Mix thoroughly. Pour 0.5 litre into 4 Wash Buckets.

15. Dissolve *RT Product Tracer* in *Product Tracer Dissolvent*. Vortex.

16. Add *Substrate Tablet* to *Substrate Buffer*. Keep in dark until use.

17. Collect *RT Reaction Plate* from incubator. Remove adhesive tape and secure strips with rubber band. Empty plate. Wash 15 times in bucket 1 and 2. Wash 15 times and soak for 5 min. in bucket 3 and 4. Leave plate to dry upside-down for 5 min. Rinse buckets.

18. Add 100 µl *RT Product Tracer* to all wells in *RT Reaction Plate*. Seal *RT Reaction Plate* and incubate for 90 min. at 33°C.

19. Pour 0.5 litre Plate wash buffer into 4 Wash Buckets. Collect *RT Reaction Plate* from incubator. Remove adhesive tape and secure strips with rubber band. Empty plate. Wash 15 times in bucket 1 and 2. Wash 15 times and soak for 5 min. in bucket 3 and 4. Remove foam from bucket 4. Take out plate and leave to dry upside-down for 5 min.

20. Vortex Substrate buffer. Add 120 µl Substrate buffer to each well in *RT Reaction Plate*. **Make sure no bubbles are present in wells.** Incubate in dark for 10 minutes at room temperature**. Read *RT Reaction Plate* at A₄₀₅. Incubate in dark for 2 to 3 hours. Read. Incubate in dark for 16 to 24 hours. Read.

21. Process data in the ExaVir Load Analyzer

**Room temperature = 18 to 33°C = 64 to 91°F

Step-by-Step Instructions

Day one

1. COLLECT AND THAW COMPONENTS AND SAMPLES

- a. Collect the following plasma samples and thaw the frozen ones at or below 37°C:

- 1 Positive control (page 4)
- 1 Negative control (page 4)
- 30 Plasma samples

- b. Collect the following kit components and thaw the frozen ones at or below 37°C:

- 1 *Sample Additive*
- 1 *Separation Gel*
- 1 *Gel Buffer 1 conc.*
- 1 *Gel Buffer 2 conc.*
- 1 *Lysis Buffer*
- 1 *Lysis Buffer Additive*
- 1 *RT Reaction Plate*
- 1 *RT Reaction Buffer*
- 1 *RT Reaction Components*
- 1 *Dilution Buffer*
- 1 *Dilution Buffer Additive*
- 1 *HIV-1 rRT Standard*
- 1 Sample Box
- 1 Separation equipment set-up
- 1 Storage Tube Rack
- 32 Plasma Processing Tubes and caps
- 32 Columns
- 48 Storage Tubes
 - 1 Piece of adhesive tape
 - 1 Plastic lid for 96-well plates

20

2. PREPARE THE PLASMA SAMPLES

- a. Add 4 ml purified water to the *Sample Additive* and vortex for ten seconds.
- b. Label Plasma Processing Tubes from 1 to 32 and put them in the Sample Box. Add 100 µl of the dissolved *Sample Additive* to each tube.
- c. Add 1 ml plasma sample, using pipette filter tips, to each tube. Add the positive and negative control to tubes 31 and 32, respectively.

- d. Add a cap to each tube and vortex for five seconds before incubating the samples in the dark for 20 minutes at room temperature**. Perform step 3 during this time.

3. PREPARE SEPARATION EQUIPMENT

- a. Make sure that all parts of the Separation equipment are clean and disinfected. Connect the Vacuum Pump, Waste Container and Waste Collector with the Vacuum Tubing and put the Column Holder on top of the Waste Collector (fig. 3).

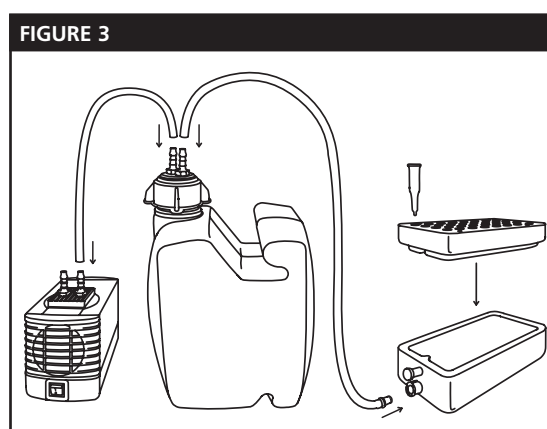

- b. Label the columns and Storage Tubes from 1 to 32. Put them in their appropriate position in the Column Holder and the Collector Tube Rack, respectively.
- c. Make sure that all channels in the Buffer Dispenser are free from blockage by putting the metal plug-plate in the channels of the Buffer Dispenser and pouring purified water into it. Lift the metal plug-plate and make sure the water flows from all channels. If not, put the metal plug-plate back and lift it again.

4. ADD SEPARATION GEL

- a. Take the Sample Box from the dark after the 20-minute incubation. Shake the *Separation Gel* bottle to homogenise the gel slurry and add 1 ml to each tube. Shake the bottle between each

30

**Room temperature = 18 to 33°C = 64 to 91°F

transfer. This is important to ensure that each tube receives an equal amount of gel. Put each cap back on the corresponding tube.

- b. Put the lid on the Sample Box and secure it with e.g. adhesive tape. Place the Sample Box on its side on the (end-over-end) mixing table and incubate at room temperature** for 30 minutes (fig. 4). Perform step 5 during this time.

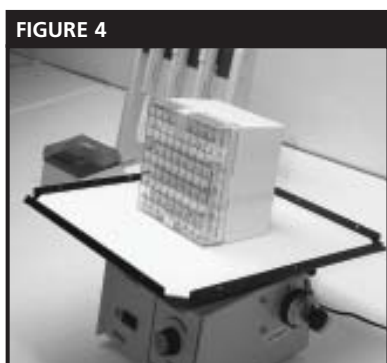

FIGURE 4

5. PREPARE BUFFERS

- a. GEL BUFFER 1: Add contents of *Gel Buffer 1 conc* to the 2-litre bottle. Rinse the bottle with 100 ml purified water and add it to the 2-litre bottle. Add 1100 ml purified water to the 2-litre bottle. Shake the bottle to mix Gel buffer 1.
- b. GEL BUFFER 2: Add contents of *Gel Buffer 2 conc* and 260 ml purified water to the 250-ml bottle. Shake the bottle to mix Gel buffer 2.
- c. LYSIS BUFFER: Add 5 ml of *Lysis Buffer* to the *Lysis Buffer Additive* and vortex for ten seconds. Transfer the dissolved contents of the *Lysis Buffer Additive* back to the *Lysis Buffer* bottle and vortex for five seconds.

6. WASH GELS WITH GEL BUFFER 1

- a. Remove the Sample Box from the mixing table after the 30-minute incubation. Vortex tube 1 until it is thoroughly mixed and pour the contents into column 1 in the Column Holder.

Vortex the remaining 31 tubes one by one and add them to the corresponding columns.

- b. Start the Vacuum Pump, apply the vacuum by closing the valve of the Waste Collector and suck the gels dry.
 - c. Turn off the Vacuum Pump. Mount the Buffer Dispenser on the Column Holder. Make sure the metal plug-plate is correctly inserted in the channels of the Buffer Dispenser.
 - d. Pour Gel buffer 1 onto the metal plug-plate until the buffer reaches the shelf just below the metal plug-plate. Lift the metal plug-plate by the handle whilst shaking it gently. Make sure the buffer flows down through all channels in the Buffer Dispenser and into the columns. Also make sure that no buffer is left in the channels. Reposition the metal plug-plate after all buffer has gone through. Remove the Buffer Dispenser and check that there is buffer in all columns.
 - e. Turn on the Vacuum Pump, and suck the gels dry. If the gel clogs and blocks the column, use a Pasteur pipette to gently resuspend the gel.
 - f. Repeat the washing procedure another three times and suck the gels dry before proceeding to step 7.
- #### 7. WASH GELS WITH GEL BUFFER 2
- a. Pour all of the Gel buffer 2 onto the metal plug-plate. Lift the metal plug-plate by the handle whilst shaking it gently. Make sure the buffer flows down through all channels in the Buffer Dispenser and into the columns. Also make sure that no buffer is left in the channels. Reposition the metal plug-plate after all buffer has gone through. Remove the Buffer Dispenser and check that there is buffer in all columns.

**Room temperature = 18 to 33°C = 64 to 91°F

- b. Turn on the Vacuum Pump, and suck the gels dry. If the gel clogs and blocks the column, use a Pasteur pipette to gently resuspend the gel.
- c. Make sure the gels are completely dry before proceeding to step 8. Turn off the Vacuum Pump.

2 8. LYSE VIRIONS

- a. Put the Collector Tube Rack with the labelled Storage Tubes into the Lysate Collector. Disconnect the Vacuum Tubing from the Waste Collector and connect it to the Lysate Collector (fig 5). Make sure that the Lysate Collector valve is open and that the Vacuum Pump is turned off.

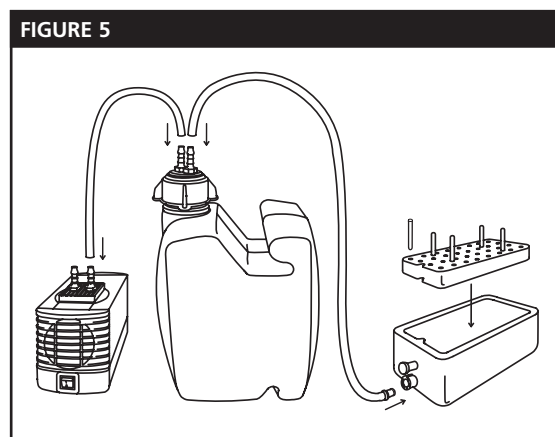

- b. Transfer the Column Holder, with the columns, from the Waste Collector to the Lysate Collector.
- c. Vortex the *Lysis Buffer* for ten seconds and add 250 μ l to the first 16 of the columns. Vortex the *Lysis Buffer* for another five seconds and add 250 μ l to the rest of the columns. Wait for two minutes. Turn on the Vacuum Pump, close the valve and keep it closed for seven seconds. Open the valve. Close the valve and keep it closed for another seven seconds. Open the valve and turn off the Vacuum Pump.
- d. Remove the Column Holder and lift out the Collector Tube Rack. Move

each Storage Tube to the Storage Tube Rack. Place tube 1 in position A1, tube 2 in B1...tube 8 in H1, tube 9 in A3 etc. Put the lid on top of the Storage Tube Rack.

9. PREPARE DILUTION BUFFER

- a. Add 5 ml of *Dilution Buffer* to the *Dilution Buffer Additive* and vortex for ten seconds. Transfer the dissolved contents of the *Dilution Buffer Additive* back to the *Dilution Buffer* and vortex for five seconds.

10. PREPARE REACTION MIXTURES AND ADD TO RT REACTION PLATE

- a. Add 4 ml of the *RT Reaction Buffer* to the *RT Reaction Components* and vortex for ten seconds. In a small bottle or tube, add 1.8 ml of this first Reaction mixture and 7.2 ml of the *Dilution Buffer* (fig. 6). Vortex for five seconds and label this bottle/tube "2RM" (second reaction mixture).

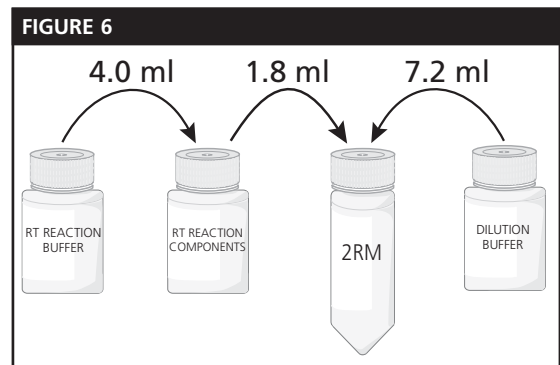

- b. Add 30 μ l of the contents of the first Reaction mixture to all wells in rows 1, 3, 5, 7, 9 and 11 of the *RT Reaction Plate* (fig. 7).
- c. Add 150 μ l of the second reaction mixture in bottle/tube "2RM" to all wells in rows 2, 4, 6, 8, 10 and 12 of the *RT Reaction Plate* (fig. 7). Cover the plate with a plastic lid.

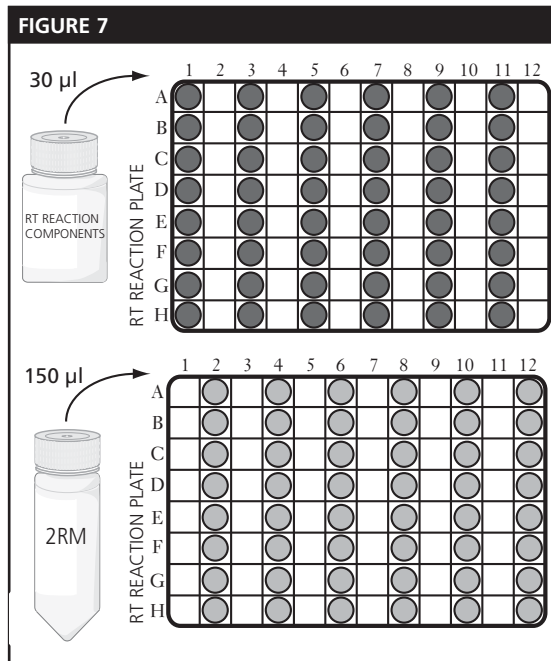

11. PREPARE HIV-1 *rRT* STANDARD SERIAL DILUTION

- a. Add 6 ml *Dilution Buffer* to the *HIV-1 rRT Standard* and vortex for ten seconds.
- b. Put 16 Storage Tubes in row 10 and 12 in the Storage Tube Rack, eight tubes in each row. Add 300 µl *Dilution Buffer* to these 16 Storage Tubes. Storage Tubes D10 to H10 are buffer blanks and do not belong to the dilution series.
- c. Add 200 µl of the dissolved *HIV-1 rRT Standard* to Storage Tube A12, change pipette tip and mix five times. Make a dilution series by transferring 200 µl from Storage Tube A12 to B12, change pipette tip and mix five times. Transfer 200 µl from B12 to C12, change pipette tip and mix five times etc, all the way to H12 (fig. 8).
- d. Change pipette tip and mix contents of Storage Tube H12 five times and transfer 200 µl from H12 to Storage Tube A10, change pipette and mix five times. Transfer 200 µl from A10 to B10, change pipette tip and mix five times. Transfer 200 µl from B10 to

C10, change pipette tip and mix five times (fig. 8).

Add the dilutions to the *RT Reaction Plate* (step 12) within 30 minutes.

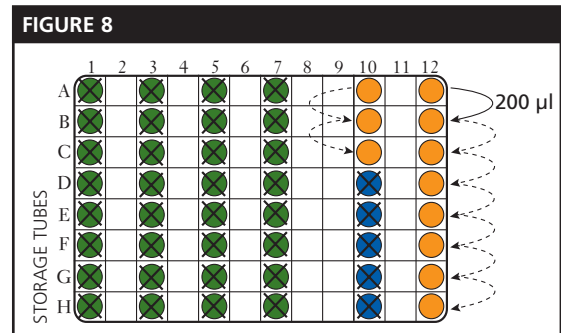

12. ADD LYSATES, BUFFER BLANKS AND HIV-1 *rRT* STANDARD TO RT REACTION PLATE

Let lid cover already added rows. Make sure not to pass the pipette over any uncovered wells in the *RT Reaction Plate*.

- a. Mix the lysates in the Storage Tubes two times with a pipette before transfer to the *RT Reaction Plate*. Add the lysates to the plate one row at a time. Add 150 µl from the Storage Tubes in row 1 to row 1 of the *RT Reaction Plate* and 30 µl to row 2. Change pipette tips and add 150 µl from the Storage Tubes in row 3 to row 3 of the *RT Reaction Plate* and 30 µl to row 4 etc (fig. 9) (see also the Standard Set-up on page 5).
- b. Let the plastic lid cover lysates. Transfer 150 µl from Storage Tubes in row 10 to row 9 of the *RT Reaction Plate* and transfer 30 µl to row 10 of the *RT Reaction Plate*. Change pipette tips and transfer 150 µl from Storage Tubes in row 12 to row 11 of the *RT Reaction Plate*. Transfer 30 µl to row 12 of the *RT Reaction Plate* (fig. 9).
- c. Seal the *RT Reaction Plate* with adhesive tape. Press the tape down firmly over each well to ensure proper sealing. Incubate for 18 to 24 hours at 33°C.

18-24 h

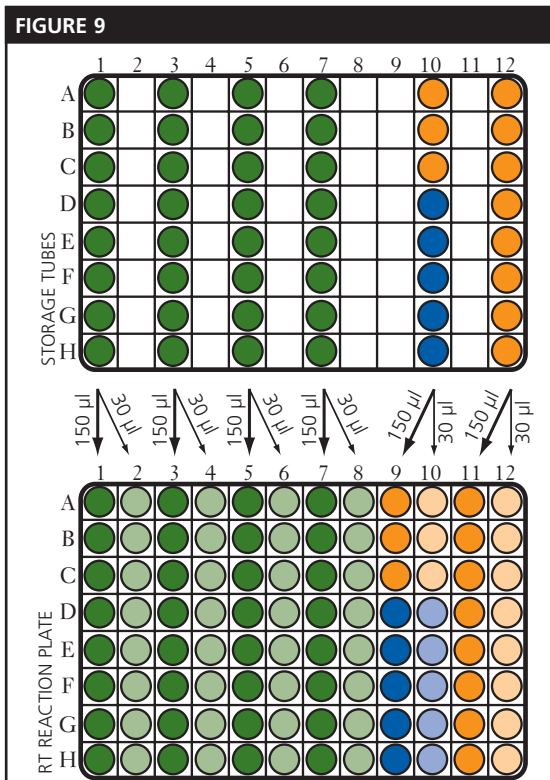

Day two

13. COLLECT AND THAW COMPONENTS

- Collect the following kit components and thaw the frozen ones at or below 37°C:

- 1 *Plate Wash Buffer conc.*
- 1 *RT Product Tracer*
- 1 *Product Tracer Dissolvent*
- 1 *Substrate Tablet*
- 1 *Substrate Buffer*
- 1 Piece of adhesive tape
- 1 Plastic lid for 96-well plates
- 2 Rubber bands

14. PREPARE PLATE WASH BUFFER

- Add two litres of purified water to a 5-litre container. Add the contents of the *Plate Wash Buffer conc* to the container. Rinse the bottle with purified water two times and pour it into the container. Adjust the volume to five litres with purified water and mix thoroughly.

- Pour 0.5 litres of the Plate wash buffer into each of the four Wash Buckets. Save the rest for later use in step 19.

15. PREPARE RT PRODUCT TRACER

- Transfer the contents of the *Product Tracer Dissolvent* to the *RT Product Tracer* and vortex for ten seconds.

16. PREPARE SUBSTRATE BUFFER

- Add the *Substrate Tablet* to the thawed *Substrate Buffer*. Store it in the dark until use in step 20.

17. STOP THE RT REACTION BY WASHING

If you are using an automatic plate washer, follow separate instructions.

- Collect the *RT Reaction Plate* from the incubator. Remove the tape carefully, pulling it diagonally from one corner to the other. Secure the strips with a rubber band. Empty the plate into the waste sink.
- Put the *RT Reaction Plate* in the first bucket with the wells facing up. Pick up the plate and empty it over the bucket. Repeat this action 15 times before moving the plate to the second bucket. Repeat the procedure in the second bucket and move the plate to the third bucket.



FIGURE 10



- Repeat the procedure and leave the plate to soak for five minutes (only for buckets three and four). Keep the

plate with the wells facing up and tap gently against the bucket side to make bubbles escape. Repeat the procedure for the last bucket.

- d. After washing in four buckets, tap the plate upside-down on dry absorbing paper. Leave it to dry upside-down on the paper for five minutes. Tap the plate again to make all bubbles in the wells disappear. Do not forget to take off the rubber band before proceeding to the next step.
- e. Throw away the used Plate wash buffer and rinse out the buckets, first with tap water and then with purified water. Turn buckets upside-down to dry before use in step 19.

 18. ADD RT PRODUCT TRACER TO RT REACTION PLATE

- a. Vortex the *RT Product Tracer* for five seconds and make sure that the lyophilised material is completely dissolved. Add 100 µl *RT Product Tracer* to each well of the *RT Reaction Plate*, without touching the bottom of the wells.
- b. Seal the plate with adhesive tape. Press the tape down firmly over each well to ensure proper sealing. Incubate for 90 minutes at 33°C.

 19. REMOVE RT PRODUCT TRACER BY WASHING
If you are using an automatic plate washer, follow separate instructions.

- a. Add 0.5 litre of the remaining Plate wash buffer to each of the four Wash Buckets. Collect the *RT Reaction Plate* from the incubator and wash it according to step 17.

To avoid bubbles in the wells when adding the Substrate buffer in step 20, let the plate sit on the bottom of the last bucket. Remove any surface bubbles by scraping them away by hand. Lift the plate carefully out of the bucket ensuring that no bubbles

are present in the wells.

Empty the remaining wash buffer from the wells by turning the plate upside-down over the wash bucket. Do not forget to tap the plate upside-down and remove the rubber band before proceeding to step 20.

20. ADD SUBSTRATE BUFFER AND READ RT REACTION PLATE

If filter tips are not used, do not use the same pipette for the *RT Product Tracer* and the *Substrate buffer*.

To avoid bubbles in the wells, use reverse pipetting when adding the *Substrate buffer*.

- a. Vortex the *Substrate buffer* for five seconds and add 120 µl to each well of the *RT Reaction Plate* without touching the bottom of the wells. Remove bubbles, if any, in the wells with a clean pipette tip for each well. Cover the plate with a plastic lid and incubate in the dark at room temperature**.
- b. Read the plate at A_{405} ten minutes after addition of the substrate (zero reading). Read the plate a second time after two to three hours and a third time the following day (16 to 24 hours after addition of substrate). Incubate the plate in the dark at room temperature** between the readings.

21. PROCESS THE DATA

- a. Calculation of the viral load values of the plasma samples is performed using the ExaVir Load Analyzer (see separate Instructions for Use).

10 min,
2-3 h,
16-24 h

**Room temperature = 18 to 33°C = 64 to 91°F

References

1. Malmsten A, Shao Z, Aperia K, Corrigan G.E, Sandström E, Källander CFR, Leitner T, Gronowitz JS. HIV-1 viral load determination based on Reverse Transcriptase activity recovered from human plasma. *J Med Virol.* 71:347-359, 2003
 2. Greengrass VL, Turnball SP, Hocking J, Dunne AL, Tachedjian G, Corrigan GE, Crowe SM. Evaluation of a low cost reverse transcriptase assay for plasma HIV-1 viral load monitoring. *Curr. HIV Res.* 3(2):183-190, 2005.
 3. Braun J, Plantier J-C, Hellot M-F, Tuailon E, Gueudin M, Damond F, Malmsten A, Corrigan GE, Simon F. A new quantitative HIV load assay based on plasma virion reverse transcriptase activity for the different types, groups and subtypes. *AIDS* 17:331-36, 2003.
 4. Weber J, Grosse F. Fidelity of human immunodeficiency virus type I reverse transcriptase in copying natural DNA. *Nucleic Acids Res.* 17, 1379-1393, 1989.
- FURTHER READING**
- Israel-Ballard K, Donovan R, Chantry C, Coutoudis A, Sheppard H, Sibeko L, Abrams B. Flash-Heat Inactivation of HIV-1 in Human Milk: A Potential Method to Reduce Postnatal Transmission in Developing Countries. *J Acquir Immune Defic Syndr.* 2007 May 17; [Epub ahead of print]
- Brandin E, Thorstensson R, Bonhoeffer S, Albert J. Rapid viral decay in simian immunodeficiency virus-infected macaques receiving quadruple antiretroviral therapy. *J Virol.* 2006 Oct;80(19):9861-4.
- Corrigan GE, Hansson EO, Morner A, Berry N, Kallander CF, Thorstensson R. Reverse Transcriptase Viral Load Correlates with RNA in SIV/SHIV-Infected Macaques. *AIDS Res Hum Retroviruses.* 2006 Sep;22(9):917-23.
- Balakrishnan P, Solomon S, Kumarasamy N, Mayer KH: Low-cost monitoring of HIV infected individuals on highly active antiretroviral therapy (HAART) in developing countries. *Indian J Med Res.* 121(4): 345-55, 2005 Review.
- Jennings C, Fiscus SA, Crowe SM, Danilovic AD, Morack RJ, Scianna S, Cachafeiro A, Brambilla DJ, Schupbach J, Stevens W, Respass R, Varnier OE, Corrigan GE, Gronowitz JS, Ussery MA, Bremer JW. Comparison of two human immunodeficiency virus (HIV) RNA surrogate assays to the standard HIV RNA assay. *J Clin Microbiol.* 43(12):5950-6, 2005
- Lombart JP, Vray M, Kafando A, Lemee V, Ouedraogo-Traore R, Corrigan GE, Plantier JC, Simon F, Braun J: Plasma virion reverse transcriptase activity and heat dissociation-boosted p24 assay for HIV load in Burkina Faso, West Africa. *AIDS* 19(12):1273-1277, 2005
- Malmsten A, Shao XW, Sjö Dahl S, Fredriksson EL, Pettersson I, Leitner T, Källander CF, Sandström E, Gronowitz JS. Improved HIV-1 viral load determination based on reverse transcriptase activity recovered from human plasma. *J Med Virol.* 76(3):291-6, 2005
- Sivapalasingam S, Essajee S, Nyambi PN, Itri V, Hanna B, Holzman R, Valentine F: Human immunodeficiency virus (HIV) reverse transcriptase activity correlates with HIV RNA load: implications for resource-limited settings. *J Clin Microbiol.* 43(8):3793-6, 2005
- Stevens G, Rekhviashvili N, Scott LE, Gonin R, Stevens W. Evaluation of two commercially available, inexpensive alternative assays used for assessing viral load in a cohort of human immunodeficiency virus type 1 subtype C-infected patients from South Africa. *J Clin Microbiol.* 2005 Feb;43(2):857-61.
- Tuailon E, Gueudin M, Lemee V, Gueit I, Roques P, Corrigan GE, Plantier JC, Simon F, Braun J. Phenotypic Susceptibility to Nonnucleoside Inhibitors of Virion-Associated Reverse Transcriptase From Different HIV Types and Groups. *J Acquir Immune Defic Syndr.* 2004 Dec 15;37(5):1543-1549.
- Crowe S, Turnbull S, Oelrichs R, Dunne A. Monitoring of human immunodeficiency virus infection in resource-constrained countries. *Clin Infect Dis.* 1;37(Suppl 1):S25-35., 2003.
- Shao X, Malmsten A, Lennerstrand J, Sönnnerborg A, Unge T, Gronowitz JS, Källander CFR. Use of HIV-1 reverse transcriptase recovered from human plasma for phenotypic drug susceptibility testing. *AIDS* 17:1463-71, 2003
- Shao XW, Hjalmarsson S, Lennerstrand J, Svennerholm B, Blomberg J, Källander CF, Gronowitz JS. Application of a colorimetric chain-termination assay for characterization of reverse transcriptase from 3'-azido-2',3'-deoxythymidine-resistant HIV isolates. *BAB.* 35(Pt 3):155-64, June 2002.
- Lennerstrand J, Hertogs K, Stammers DK, Larder BA. Correlation between viral resistance to zidovudine and resistance at the reverse transcriptase level for a panel of human immunodeficiency virus type 1 mutants. *J Virol.* 75(15): 7202-5, Aug 2001.
- Lennerstrand J, Stammers DK, Larder BA. Biochemical mechanism of human immunodeficiency virus type 1 reverse transcriptase resistance to stavudine. *Antimicrob Agents Chemother.* 45(7): 2144-6, July 2001.
- Corrigan GE, Al-Khalili L, Malmsten A, Thorstensson R, Fenyö E-M, Källander CFR, and Gronowitz JS. Differences in reverse transcriptase activity versus p24 antigen detection in cell culture, when comparing a homogenous group of HIV-1 subtype B viruses with a heterogeneous group of divergent strains. *AIDS Res. Hum. Retroviruses.* 14(4), 347-352, 1998.
- Awad RJ-K, Corrigan GE, Ekstrand D H L, Thorstensson R, Källander CFR and Gronowitz JS. Measurement of levels of HIV-1 reverse transcriptase (RT) and RT activity blocking antibody in human serum by a new standardized colorimetric assay. *J.Clin. Microb.* 35, 1080-1089, 1997.

Cavidi AB

Uppsala Science Park
SE-751 83 Uppsala, Sweden

Tel: + 46 18 55 20 40

Fax: + 46 18 55 20 41

e-mail: info@cavidi.se

www.cavidi.com